

Iris Power MCPDTracII™

Continuous On-line Partial Discharge Monitoring for
Medium Voltage Switchgear and Isolated Phase Bus



IRIS POWER MCPDTracII

IRIS POWER MCPDTRACII SYSTEM FOR PD MONITORING OF MV SWITCHGEAR

The Iris Power MCPDTracII system is an effective and economical means of providing automated, continuous partial discharge (PD) measurement for switchgear and isolated phase bus (IPB) applications. The Iris Power MCPDTracII system consists of multiple sets of permanently installed capacitive couplers connected at intervals to the main bus-bars, an Iris Power MCPDTracII monitor, plus digital communication. Alternatively, the MCPDTracII can be operated "stand alone" for periodic downloading of stored PD data. Continuous monitoring is recommended for switchgear and IPB because PD in this equipment can be significantly influenced by ambient humidity, and so more frequent measurements along with logging of relative humidity will more reliably reveal any variation in activity levels due to insulation aging. Using the networking features of the Iris Power MCPDTracII and implementing remote data collection, any unexpected arc flash hazard and personal injury can be avoided. The Iris Power MCPDTracII system is equipped with data exchange capability to interface with modern plant automation systems.

MONITOR UP TO 16 CELLS

The Iris Power MCPDTracII is an extension of the PDTracII family, a third generation continuous on-line monitor that provides maintenance professionals with an opportunity to automate PD testing. Two versions are available: one MCPDTracII can connect to up to 24 couplers or up to 48 couplers. One monitor can be used to monitor many cubicles or even more than one switchgear line-up,

depending on the distance. The Iris Power MCPDTracII monitor also allows for the possibility of integrating important operating conditions needed for trending PD activity, and will trigger a remote alarm, indicating the need for a more detailed analysis. The monitor uses the same 80 pF capacitive sensors that have been permanently installed on thousands of motors, generators and switchgear (3.3kV and higher) over the last 20 years by utilities and other industries around the world.

LOW RISK OF FALSE INDICATIONS

The Iris Power MCPDTracII monitor includes our unique and rigorously researched methods to overcome the electrical interference (noise) typical in most plant environments. This ensures reliable and repeatable measurements with a low probability of false indications. The collected data can be easily interpreted by maintenance professionals after participating in a 2-day training seminar offered by Qualitrol-Iris Power's experienced engineering staff.

PD SENSORS

Facilities that have existing 80 pF couplers installed in their switchgear and IPB can easily add the Iris Power MCPDTracII monitor to the system by connecting it to the existing coupler termination panel within the plant. This does not require an outage and the installation effort is limited to providing power to the monitor, wiring the alert relay, sensor/probe if the remote I/O option is selected, and running a communication link to a local control room computer or an Ethernet LAN/WAN.



Installed Capacitive Couplers

Switchgear and IPB not previously equipped with Iris Power capacitive couplers must have the 80 pF PD sensors installed during a suitable outage.

DATA PRESENTATION

The Iris Power MCPDTracII monitor continuously collects PD data and archives data which are used to produce 2D and 3D (phase resolved) plots as well as summary numbers (Qm and NQN), which are used for trending and comparison with other units. Using the Windows™-based software provided with the monitor, the archived PD data can be downloaded locally over a USB port, or remotely using Ethernet (TCP/IP) network communication.

Important operating conditions such as equipment temperature, voltage, current, ambient humidity and ambient temperature can be recorded and stored with the archived PD data. These parameters are useful for trending of the partial discharge activity and explaining variation in levels.

IRIS POWER MCPDTracII

FEATURES

- The Iris Power MCPDTracII monitor contains superior noise separation technology based on filtering and pulse shape analysis, reliably distinguishing partial discharges from electrical interference (noise) and discharge from other equipment connected by long power cables, in order to suppress false indications (alarms). Noise from distant equipment is suppressed when the power cable length is more than 30m or 100 ft of power cable.
- Data collected by the Iris Power MCPDTracII monitor is compatible with the existing TGA/PDA technology. Users with existing sensor installations can commission the system without an equipment outage. Data is easily confirmed and further analyzed with the Iris Power TGA-B™ or Iris Power PDA-IV™ portable instruments.
- The MCPDTracII monitors coupler sets at intervals on an IPB or bus.

- The Iris Power MCPDTracII monitor performs continuous PD measurements with advanced alert features, allowing minimal intervention by maintenance personnel. In response to an alert indication, users can review the pulse height analysis plots, and the 24-window phase resolved PD plots using basic interpretation skills to confirm the cause of the alert.
- Alert Output is a dedicated relay fitted within the monitor. The relay has a solid state latching contact that can activate a remote indicator, which must be reset by the user. The alert threshold conditions are configurable through the operating software. The alert output may also be connected to a plant monitoring system.
- The Iris Power MCPDTracII monitor is equipped with ambient sensor input modules to enhance data gathering for trending and analysis. Available inputs include ambient temperature and ambient humidity, as they may impact PD readings.

- USB memory stick port for downloading stored data without a laptop computer.
- Qualitrol-Iris Power has extensive experience with continuous on-line PD monitoring. Over 2,000 continuous on-line PD monitors have been installed.
- Networking with an Ethernet port for remote diagnostics, downloading, configuration with Iris Power software.
- Modbus over Ethernet protocol included for interfacing to third party applications.

OPTIONS

- Remote I/O over Ethernet with four analog inputs proportional to operating conditions such as equipment temperature, voltage, and current. These conditions are recorded for trending and analysis.
- Remote alert relay over Ethernet.

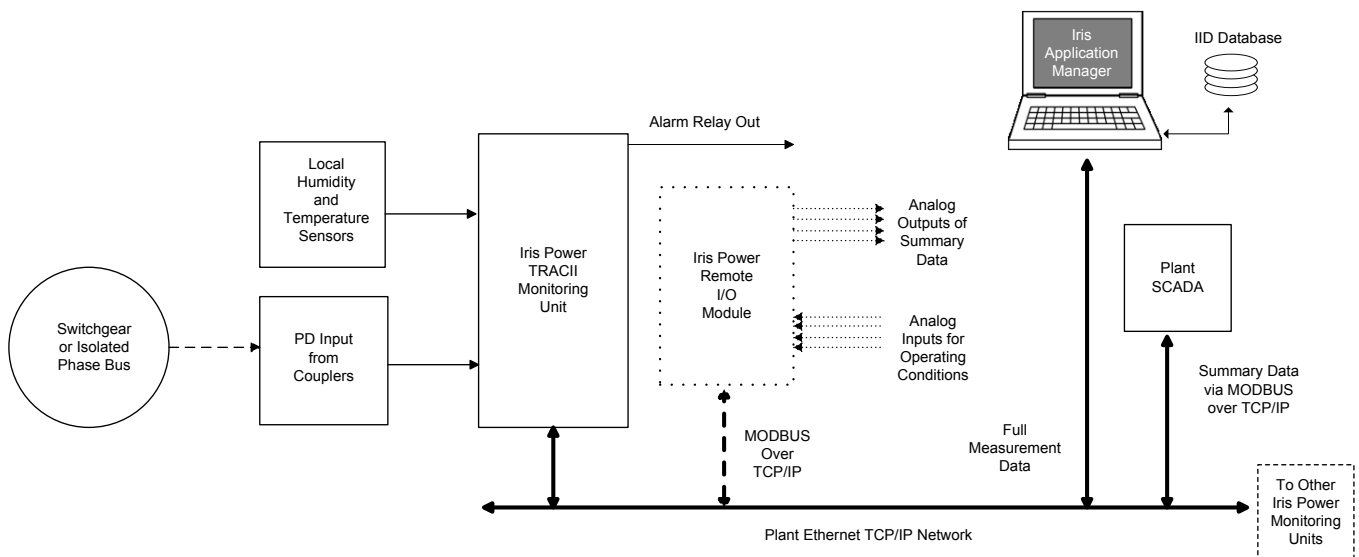

IRIS POWER MCPDTracII

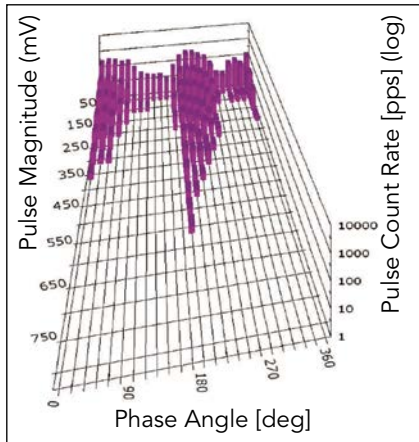

Phase-resolved PD output



Electrical tracking of high voltage bus due to contamination

WHAT IS PARTIAL DISCHARGE?

Partial discharges (PD) are small electrical sparks that occur within the high voltage electrical insulation in dry type transformers, and air-insulated switchgear. PD occurs whenever there are small air gaps or voids in or on the surface of the insulation. Normally, well-made apparatus that are in good condition display very little or no PD activity. However, over 60 years experience has shown that as insulation deteriorates from operation at high temperatures, or contamination from moisture and other chemicals, the PD activity will increase by a factor of ten or more. Thus, on-line PD monitoring detects the main root causes of failure. Since PD monitoring can be performed during normal apparatus operation, and generally gives two or more years of warning indicating a risk of failure, on-line PD monitoring has become a very powerful tool for predictive maintenance.

Some benefits of PD monitoring are:

- Increased availability of equipment
- Plan maintenance based on actual conditions
- Significant reduction of in-service failures.

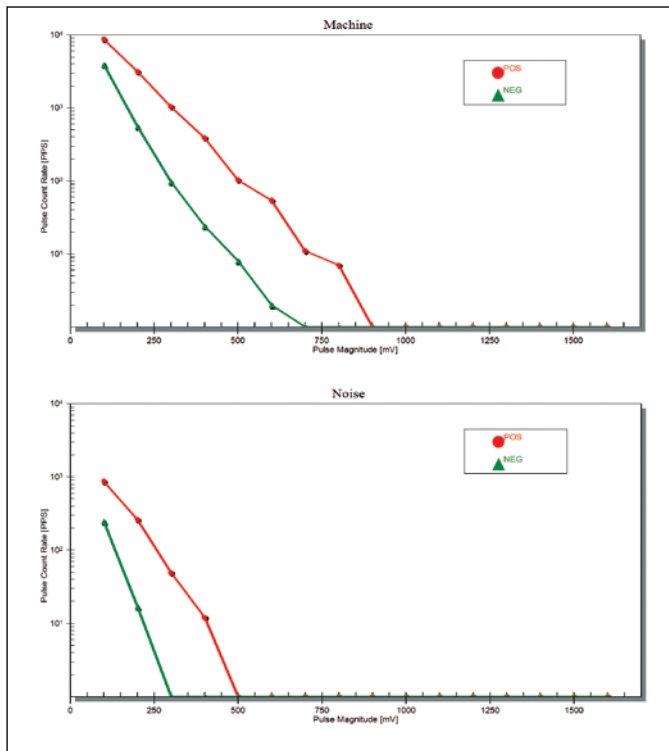

PD Pulse Magnitude Output

Iris Power MCPDTracII, Iris Power PDTracII, Iris Power PDA-IV, Iris Power TGA-B are trademarks of Qualitrol-Iris Power. Windows is a registered trademark of Microsoft Corporation in the United States and other countries.

QUALITROL-IRIS POWER HAS BEEN THE WORLD LEADER IN MOTOR AND GENERATOR WINDING DIAGNOSTICS SINCE 1990, PROVIDING A FULL LINE OF ON-LINE AND OFF-LINE TOOLS, AS WELL AS COMMISSIONING AND CONSULTING SERVICES.



A QUALITROL Company

www.irispower.com

www.qualitrolcorp.com

Iris Power LP
3110 American Drive
Mississauga, ON, Canada L4V 1T2
Phone: +1-905-677-4824
Fax: +1-905-677-8498
Sales.iris@qualitrolcorp.com

Qualitrol Company LLC
1385 Fairport Road
Fairport, NY, USA 14450
Phone: +1-585-586-1515
Fax: +1-585-377-0220



QUALITROL
Defining Reliability

Ver 2 • 7/14